

Isolated converter for RTD and resistance configurable by Dip-Switch or PC
DAT 4531 B

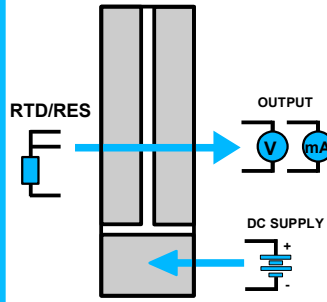

FEATURES

- Configurable input for RTD and resistance
- Configurable output in current or voltage
- Configurable by dip-switch or PC
- High accuracy
- On-field reconfigurable
- Galvanic isolation among the ways
- UL / CE mark
- Suitable for DIN rail mounting in compliance with EN-50022 and EN-50035

GENERAL DESCRIPTION

The isolated converter DAT 4531 B is able to measure and linearise the standard RTDs and resistances with 2 or 3 wires cable compensation . In function of programming, the measured values are converted in a current or voltage signal. The device guarantees high accuracy and performances stability both versus time and temperature. The programming is made by the dip-switch located in the window on the side of the enclosure. By means of dip-switches it is possible to select the input type and range and the output type without recalibrate the device. Moreover, by Personal Computer the user can program all of the device's parameters for his own necessity. For all the sensors it is possible to set the cable compensation with 2 or 3 wires. Moreover it is available the option of alarm for signal interruption (burn-out) that allows to set the output value as high or low out of scale . The 1500 Vac galvanic isolation on all ways (input, output and power supply) eliminates the effects of all ground loops eventually existing and allows the use of the converter in heavy environmental conditions found in industrial applications. The DAT 4531 B is in compliance with the Directive UL 61010-1 for US market and with the Directive CSA C22.2 No 61010-1 for the Canadian market. It is housed in a plastic enclosure of 12.5 mm thickness suitable for DIN rail mounting in compliance with EN-50022 and EN-50035 standards.

USER INSTRUCTIONS

The connections must be made as shown in the section "Connections". It is possible to configure the converter on field by dip-switch or Personal Computer as shown in the section " Programming ". The configuration by Dip-switches can be made also if the device is powered (note: after the configuration the device takes some seconds to provide the right output measure).

TECHNICAL SPECIFICATIONS (Typical at 25 °C and in nominal conditions)

INPUT				OUTPUT				POWER SUPPLY		
Input type	Min	Max	Min.Span	Output type	Min	Max	Min Span			
RTD (2, 3 wires)				Current	0 mA	20 mA	4 mA	Power supply voltage	18 .. 30 Vdc	
Pt100	-200°C	850°C	50°C	Voltage	0 V	10 V	1 V	Reverse polarity protection	60 Vdc max	
Pt1000	-85°C	185°C	30°C	Output resolution				Current consumption		
Ni100	-60°C	180°C	50°C	Current	7 uA			Current output	35 mA max.	
Ni1000	-60°C	150°C	30°C	Voltage	4 mV			Voltage output	20 mA max.	
RES. (2, 3 wires)				Burn-out values				ISOLATION		
	0 Ω	500 Ω	50 Ω	Max. output value	22 mA or 10.6 V			Among all the ways	1500 Vac,	
	0 Ω	2000 Ω	50 Ω	Min. output value	0 mA or -0.6 V				50 Hz, 1 min	
Accuracy (1)				Output load Resistance - Rload				ENVIRONMENTAL CONDITIONS		
RTD	the higher of ±0.1% and ±0.2°C			Current output	< 500 Ω			Operative Temperature	-20°C .. +60°C	
Low Res.	the higher of ±0.1% and ±0.15 Ω			Voltage output	> 10 KΩ			UL Operative Temperature	-10°C .. +60°C	
High Res.	the higher of ±0.2% and ± 1 Ω			Short circuit current	26 mA max.			Storage Temperature	-40°C.. +85°C	
Linearity (1)				Response time (10+ 90%)				Humidity (not condensed)	0 .. 90 %	
RTD	± 0.1 % f.s.				about 500 ms			Maximum Altitude	2000 m	
Sensor excitation current				MECHANICAL SPECIFICATIONS						
RTD,Res	500 uA			Material						Self-extinguish plastic
Line resistance influence (1)				IP Code						IP20
RTD 3 wires	0.05%/Ω (50 Ω max balanced)			Wiring						wires with diameter
Thermal drift (1)				Tightening Torque						0.8+2.1 mm ² /AWG 14-18
Full scale	± 0.01% / °C			Mounting						0.8 N m
				Weight						in compliance with DIN rail standard EN-50022 and EN-50035
				File Number						about 90 g.
				CERTIFICATIONS						
				EMC (for industrial environments)						
				Immunity						EN 61000-6-2
				Emission						EN 61000-6-4
				UL						
				US Standard						UL 61010-1
				Canadian Standard						CSA C22.2 No 61010-1
				CCN						NRAQ/NRAQ7
				Typology						Open Type device
				Classification						Industrial Control Equipment
				File Number						E352854

(1)referred to the input Span (difference between max. and min.)

PROGRAMMING

CONFIGURATION BY PC

By software DATESOFT it is possible to:

- set the default programming of the device;
- program the options not available with the dip-switch;
(burn-out level, etc...);
- read, in real time, the input and output measures;
- follow the dip-switches configuration wizard.

To configure the device follow the next steps:

- 1) Power-on the device.
- 2) Open the protection plastic label on the front of the device.
- 3) Connect the interface PRODAT to the PC (COM port) and to the device (PGRM connector).
- 4) Open DATESOFT.
- 5) Select the COM port in use.
- 6) Click on "Open COM".
- 7) Click on "Program".
- 8) Set the programming data.
- 9) Click on "Write" to send the programming data to the device.

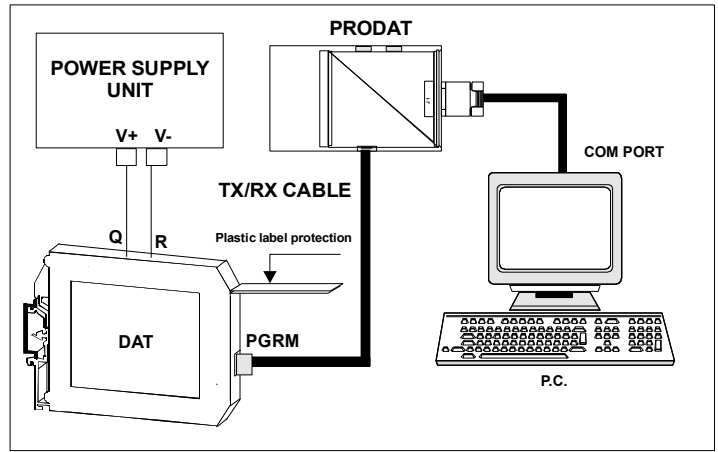

Warning: during these operations the device must always be powered and the TX/RX cable always connected.
For information about DATESOFT refer to the software's user guide.

CONFIGURATION BY DIP-SWITCHES

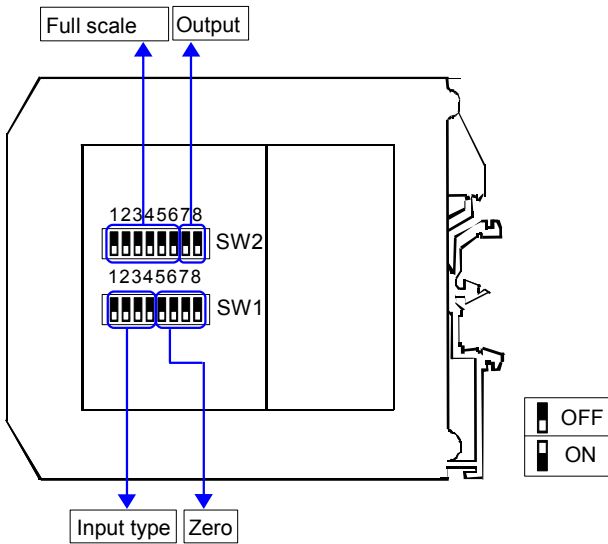

- 1) Open the suitable door on the side of the device.
- 2) Set the input type by the dip-switch SW1 [1..4] (see TAB.1)
- 3) Set the minimum input scale value (Zero) by the dip-switch SW1 [5..8] (see TAB.3)
- 4) Set the maximum input value (Full scale) by the dip-switch SW2 [1..6] (see TAB.3)
- 5) Set the output type by the dip-switch SW2 [7..8] (see TAB.2)

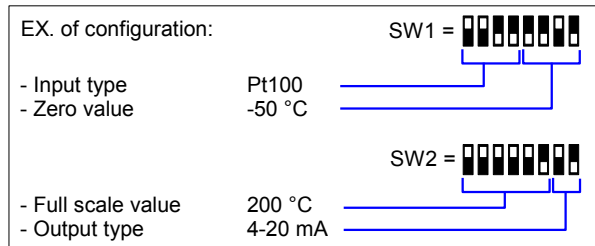

NOTE:

- It is also possible to set the dip-switches using the wizard of the configuration software following the procedure described in the section "Configuration by PC" until the step 6 and clicking on "Switch".

DIP-SWITCH CONFIGURATION TABLES

TAB.1
Input type settings

SW1	SW1
1 2 3 4	1 2 3 4
	EPROM *
	R 2KΩ
	R 500Ω
	Pt100
	Ni100
	Pt1000
	Ni1000

TAB.2
Output settings

SW2	
7 8	
	0-20 mA
	4-20 mA
	0-10 V
	0-5 V

NOTES:

* For all the input type selected by dip-switches, the compensation of wires is fixed at 3.

* To configure the range for the input type selected (TAB.1) refer to the section of the TAB.3 on next page relative to it (ex: for Pt100 use the table TAB.3c).

* If the dip-switches SW1 [1..4] are all set in the position 0 ("EPROM"), the device will follow the configuration programmed by PC (input type and range, output type and range and options).

* If the dip-switches SW1 [5..8] are all set in the position 0 ("Default"), the device will follow the input scale programmed by PC for the input type selected by the dip-switches SW1 [1..4]

* Eventual wrong dip-switches settings will be signalled by the blinking of the led "PWR".

INSTALLATION INSTRUCTIONS

The device is suitable for fitting to DIN rails in the vertical position. For optimum operation and long life follow these instructions:

When the devices are installed side by side it may be necessary to separate them by at least 5 mm in the following cases:

- If panel temperature exceeds 45°C.
- Use of high power supply value (> 27 Vdc).
- Use of output current.

Make sure that sufficient air flow is provided for the device avoiding to place raceways or other objects which could obstruct the ventilation slits. Moreover it is suggested to avoid that devices are mounted above appliances generating heat; their ideal place should be in the lower part of the panel.

Install the device in a place without vibrations.

Moreover it is suggested to avoid routing conductors near power signal cables (motors, induction ovens, inverters etc...) and to use shielded cable for connecting signals.

ISOLATION STRUCTURE



CONNECTIONS

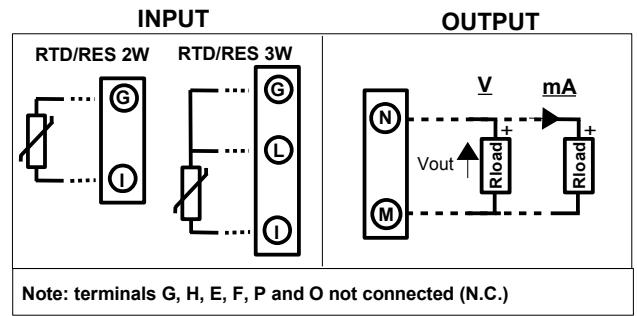

POWER SUPPLY(*)

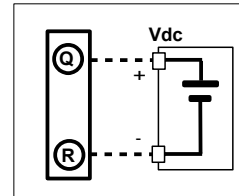

(*) Note: for UL installation the device must be powered using a power supply unit classified NEC class 2 or SELV

LIGHT SIGNALLING

LED	COLOUR	STATE	DESCRIPTION
PWR	GREEN	ON	Device powered
		OFF	Device not powered
		BLINKING	Wrong dip-switches setting

DIMENSIONS (mm)

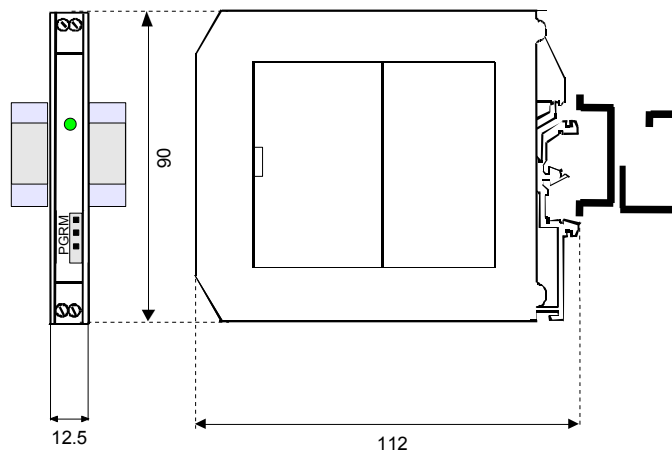

HOW TO ORDER

The device is provided as requested on the Customer's order. Refer to the section "Programming" to determine the input and output ranges. In case of the configuration is not specified, the parameters must be set by the user.

ORDER CODE EXAMPLE:

DAT 4531B / Pt100 / 0 ÷ 200 °C / 4 ÷ 20 mA / 3 wires

