

**FEATURES**

- Configurable input for PTC, NTC and Pot.
- Double output configurable in current or voltage
- Configurable by dip-switch or PC
- High accuracy
- On-field reconfigurable
- Galvanic isolation among the ways
- UL / CE mark
- Suitable for DIN rail mounting in compliance with EN-50022 and EN-50035

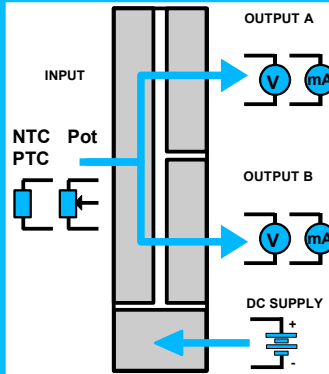

**GENERAL DESCRIPTION**

The isolated doubler/converter DAT 4631 C is able to measure and linearise the standard PTC and NTC sensors and potentiometers. In function of programming, the measured values are converted in a current or voltage signal. The device guarantees high accuracy and performances stability both versus time and temperature.

The programming is made by the dip-switch located in the window on the side of the enclosure. By means of dip-switches it is possible to select the input type and range and the output type without recalibrate the device.

Moreover, by Personal Computer the user can program all of the device's parameters for his own necessity; the configuration by PC allows to program the two outputs with two independent settings.

Moreover it is available the option of alarm for signal interruption (burn-out) that allows to set the output value as high or low out of scale .

The 1500 Vac galvanic isolation on all ways (input, outputs and power supply) eliminates the effects of all ground loops eventually existing and allows the use of the converter in heavy environmental conditions found in industrial applications.

The DAT 4631 C is in compliance with the Directive UL 61010-1 for US market and with the Directive CSA C22.2 No 61010-1 for the Canadian market.

It is housed in a plastic enclosure of 12.5 mm thickness suitable for DIN rail mounting in compliance with EN-50022 and EN-50035 standards.

**USER INSTRUCTIONS**

The connections must be made as shown in the section "Connections".

It is possible to configure the converter on field by dip-switch or Personal Computer as shown in the section " Programming ". The configuration by dip-switches can be made also if the device is powered (note: after the configuration the device takes some seconds to provide the right output measure ).

**TECHNICAL SPECIFICATIONS (Typical at 25 °C and in nominal conditions)**

INPUT				OUTPUT (2 channels)				POWER SUPPLY	
Input type	Min	Max	Min.Span	Output type	Min	Max	Min Span		
<b>PTC</b> KTY81-210 KTY81-220 KTY84-130 KTY84-150	-55°C -55°C -40°C -40°C	150°C 150°C 300°C 300°C	50°C 50°C 50°C 50°C	Current Voltage	0 mA 0 V	20 mA 10 V	4 mA 1 V	Power supply voltage	18 .. 30 Vdc
<b>NTC</b> Coster 10K Coster 1K	-10°C -30°C	100°C 40°C	50°C 25°C	<b>Output resolution</b> Current Voltage		7 uA 4 mV		Reverse polarity protection	60 Vdc max
<b>Pot.</b> (Rnom.< 50KΩ)	0 %	100 %	10 %	<b>Burn-out values</b> Max. output value Min. output value		22 mA or 10.6 V 0 mA or -0.6 V		<b>Current consumption</b> Current output Voltage output	55 mA max. 25 mA max.
<b>Accuracy</b> (1) PTC, NTC Potentiometer	the higher of ±0.1% and ±0.2°C ± 0.05 % f.s.			<b>Output load Resistance - Rload</b> Current output Voltage output Short circuit current	< 500 Ω > 10 KΩ 26 mA max.			<b>ISOLATION</b> Among all the ways	1500 Vac, 50 Hz, 1 min
<b>Linearity</b> (1) PTC, NTC	± 0.1 % f.s.			<b>Response time (10+ 90%)</b>	about 500 ms			<b>ENVIRONMENTAL CONDITIONS</b> Operative Temperature UL Operative Temperature Storage Temperature Humidity (not condensed) Maximum Altitude Installation Category of installation Pollution Degree	-20°C .. +60°C -10°C .. +60°C -40°C.. +85°C 0 .. 90 % 2000 m Indoor II 2
<b>Sensor excitation current</b> PTC, NTC	500 uA							<b>MECHANICAL SPECIFICATIONS</b> Material IP Code Wiring Tightening Torque Mounting Weight	Self-extinguish plastic IP20 wires with diameter 0.8÷2.1 mm <sup>2</sup> /AWG 14-18 0.8 N m in compliance with DIN rail standard EN-50022 and EN-50035 about 90 g.
<b>Thermal drift</b> (1) Full scale	± 0.01% / °C							<b>CERTIFICATIONS</b> <b>EMC ( for industrial environments)</b> Immunity Emission <b>UL</b> US Standard Canadian Standard CCN Typology Classification File Number	EN 61000-6-2 EN 61000-6-4 UL 61010-1 CSA C22.2 No 61010-1 NRAQ/NRAQ7 Open Type device Industrial Control Equipment E352854

(1)referred to the input Span (difference between max. and min.)

## PROGRAMMING

### CONFIGURATION BY PC

By software DATESOFT it is possible to:

- set the default programming of the device;
- program the options not available with the dip-switch; (burn-out level, etc...);
- read, in real time, the input and output measures;
- follow the dip-switches configuration wizard.

To configure the device follow the next steps:

- 1) Power-on the device.
- 2) Open the protection plastic label on the front of the device.
- 3) Connect the interface PRODAT to the PC (COM port) and to the device (PGRM connector).
- 4) Open DATESOFT.
- 5) Select the COM port in use.
- 6) Click on "Open COM".
- 7) Click on "Program".
- 8) Set the programming data.
- 9) Click on "Write" to send the programming data to the device.

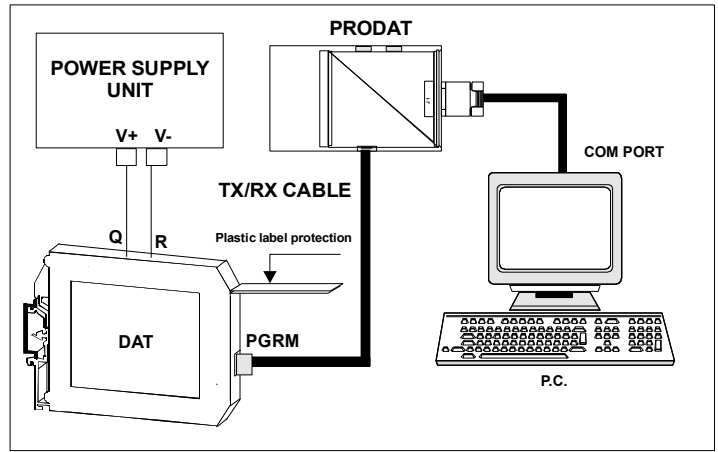

**Warning: during these operations the device must always be powered and the TX/RX cable always connected.**  
**For information about DATESOFT refer to the software's user guide.**

### CONFIGURATION BY DIP-SWITCHES

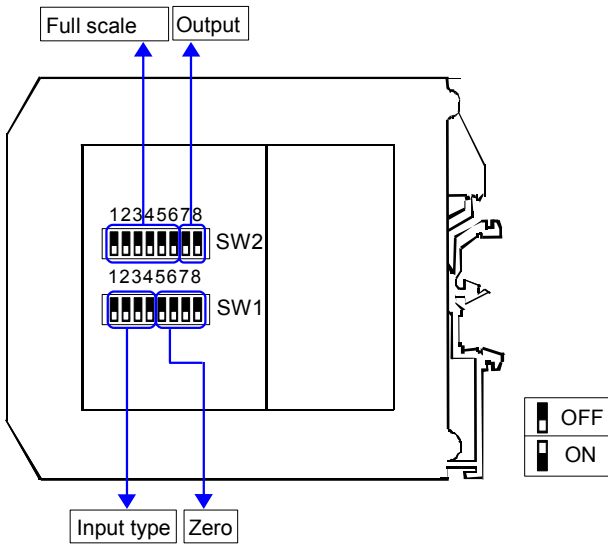

- 1) Open the suitable door on the side of the device.
- 2) Set the input type by the dip-switch SW1 [1..4] (see TAB.1)
- 3) Set the minimum input scale value (Zero) by the dip-switch SW1 [5..8] (see TAB.3)
- 4) Set the maximum input value (Full scale) by the dip-switch SW2 [1..6] (see TAB.3)
- 5) Set the output type by the dip-switch SW2 [7..8] (see TAB.2)

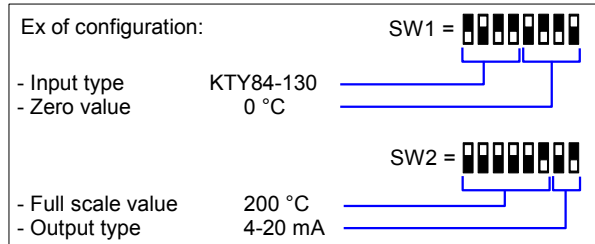

NOTE:

- It is also possible to set the dip-switches using the wizard of the configuration software following the procedure described in the section "Configuration by PC" until the step 6 and clicking on "Switch".

### DIP-SWITCH CONFIGURATION TABLES

TAB.1  
Input type settings

SW1	1	2	3	4	
<input type="checkbox"/>	<input type="checkbox"/>	<input type="checkbox"/>	<input type="checkbox"/>	<input type="checkbox"/>	EPROM *
<input type="checkbox"/>	<input type="checkbox"/>	<input type="checkbox"/>	<input type="checkbox"/>	<input type="checkbox"/>	Pot
<input type="checkbox"/>	<input type="checkbox"/>	<input type="checkbox"/>	<input type="checkbox"/>	<input type="checkbox"/>	KTY81-210 KTY81-220
<input type="checkbox"/>	<input type="checkbox"/>	<input type="checkbox"/>	<input type="checkbox"/>	<input type="checkbox"/>	KTY84-130 KTY84-150
<input type="checkbox"/>	<input type="checkbox"/>	<input type="checkbox"/>	<input type="checkbox"/>	<input type="checkbox"/>	Coster 10K
<input type="checkbox"/>	<input type="checkbox"/>	<input type="checkbox"/>	<input type="checkbox"/>	<input type="checkbox"/>	Coster 1K

TAB.2  
Output type settings

SW2	7	8	
<input type="checkbox"/>	<input type="checkbox"/>	<input type="checkbox"/>	0-20 mA
<input type="checkbox"/>	<input type="checkbox"/>	<input type="checkbox"/>	4-20 mA
<input type="checkbox"/>	<input type="checkbox"/>	<input type="checkbox"/>	0-10 V
<input type="checkbox"/>	<input type="checkbox"/>	<input type="checkbox"/>	0-5 V

NOTES:

\* To configure the range for the input type selected (TAB.1) refer to the section of the TAB.3 on next page relative to it (ex: for Potentiometer use the table TAB.3b).

\* If the dip-switches SW1 [1..4] are all set in the position 0 ("EPROM"), the device will follow the configuration programmed by PC (input type and range, output type and range and options).

\* If the dip-switches SW1 [5..8] are all set in the position 0 ("Default"), the device will follow the input scale programmed by PC for the input type selected by the dip-switches SW1 [1..4]

\* Eventual wrong dip-switches settings will be signalled by the blinking of the led "PWR".

TAB.3a – Settings for PTC, NTC

Zero		Full scale													
SW1 5 6 7 8		°C		SW2 1 2 3 4 5 6		°C		SW2 1 2 3 4 5 6		°C		SW2 1 2 3 4 5 6		°C	
	Default		Default		75		210		370		380		390		400
	-200		0		80		220		380		390		400		425
	-150		5		85		230		390		400		425		450
	-100		10		90		240		400		425		450		475
	-50		15		95		250		425		450		475		500
	-40		20		100		260		450		500		525		550
	-30		25		110		270		500		525		550		600
	-20		30		120		280		525		550		600		650
	-10		35		130		290		550		600		650		700
	0		40		140		300		600		650		700		750
	5		45		150		310		650		700		750		800
	10		50		160		320		700		750		800		850
	20		55		170		330		750		800		850		
	30		60		180		340		800						
	50		65		190		350								
	100		70		200		360								

TAB.3b –Settings for Potentiometer

Zero		Full scale													
SW1 5 6 7 8		%		SW2 1 2 3 4 5 6		%		SW2 1 2 3 4 5 6		%		SW2 1 2 3 4 5 6		%	
	Default		Default		34		66		98		100		100		100
	0		5		36		68		100		100		100		100
	15		6		38		70		100		100		100		100
	20		8		40		72		100		100		100		100
	25		10		42		74		100		100		100		100
	30		12		44		76		100		100		100		100
	35		14		46		78		100		100		100		100
	40		16		48		80		100		100		100		100
	45		18		50		82		100		100		100		100
	50		20		52		84		100		100		100		100
	55		22		54		86		100		100		100		100
	60		24		56		88		100		100		100		100
	65		26		58		90		100		100		100		100
	70		28		60		92		100		100		100		100
	75		30		62		94		100		100		100		100
	80		32		64		96		100		100		100		100

## INSTALLATION INSTRUCTIONS

The device is suitable for fitting to DIN rails in the vertical position. For optimum operation and long life follow these instructions:

**When the devices are installed side by side it may be necessary to separate them by at least 5 mm in the following cases:**

- If panel temperature exceeds 45°C.
- Use of high power supply value (> 27 Vdc).
- Use of output current.

Make sure that sufficient air flow is provided for the device avoiding to place raceways or other objects which could obstruct the ventilation slits. Moreover it is suggested to avoid that devices are mounted above appliances generating heat; their ideal place should be in the lower part of the panel.

Install the device in a place without vibrations.

Moreover it is suggested to avoid routing conductors near power signal cables (motors, induction ovens, inverters etc...) and to use shielded cable for connecting signals.

## ISOLATION STRUCTURE

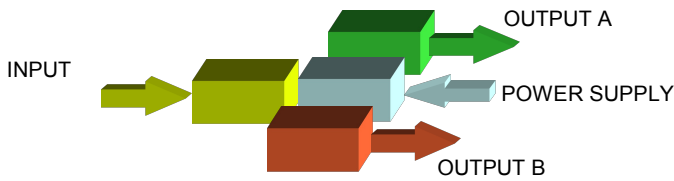

## LIGHT SIGNALLING

LED	COLOUR	STATE	DESCRIPTION
PWR	GREEN	ON	Device powered
		OFF	Device not powered
		BLINKING	Wrong dip-switches setting

## CONNECTIONS

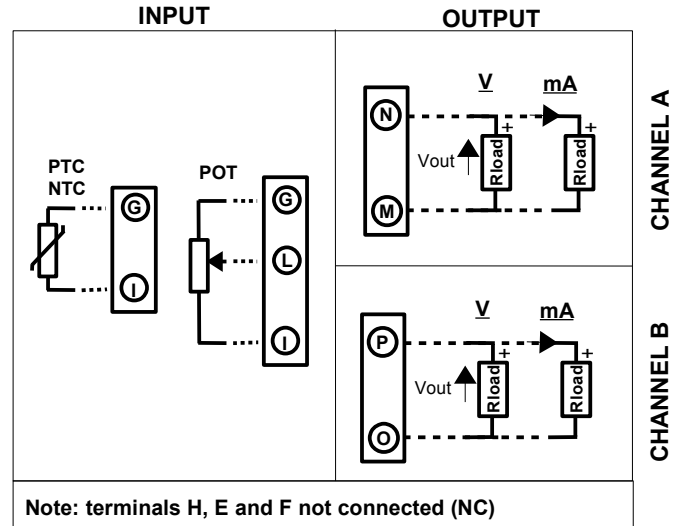

## POWER SUPPLY(\*)

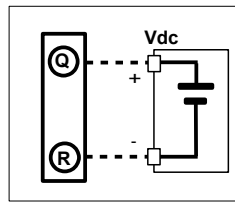

(\*) Note: for UL installation the device must be powered using a power supply unit classified NEC class 2 or SELV

## DIMENSIONS (mm)

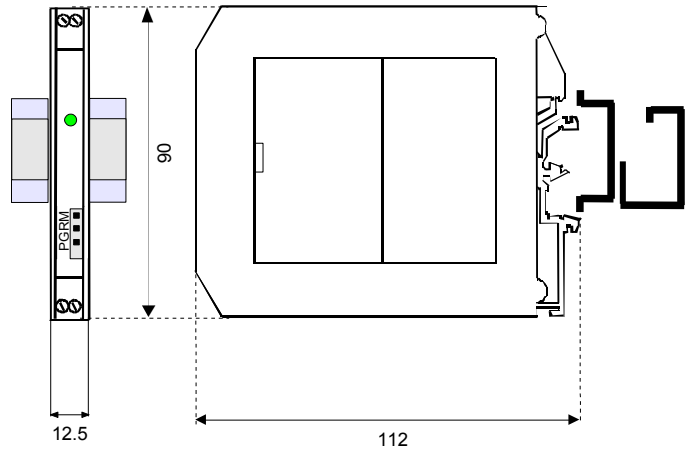

## HOW TO ORDER

The device is provided as requested on the Customer's order. Refer to the section "Programming" to determine the input and output ranges. In case of the configuration is not specified, the parameters must be set by the user.

### ORDER CODE EXAMPLE:

**DAT 4631C / [KTY84-130] / [0 ÷ 200 °C] / [4 ÷ 20 mA]**

