

FEATURES

- Configurable input for voltage and current
- Configurable output in current or voltage
- Calculation function (two independent outputs)
- Configurable by dip-switch or PC
- High accuracy
- On-field reconfigurable
- Galvanic isolation among all the ways
- EMC compliant – CE mark
- Suitable for DIN rail mounting in compliance with EN-50022 and EN-50035

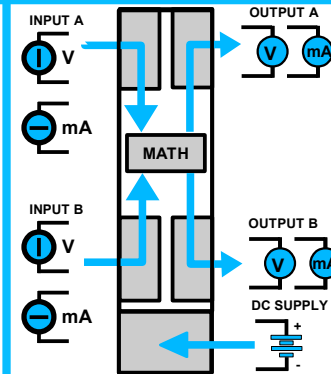

GENERAL DESCRIPTION

The isolated converter DAT 4632 D is able to measure voltage and current signals, execute a programmable mathematical function and provide on output a normalized current or voltage signal. The device guarantees high accuracy and performances stability both versus time and temperature. The programming is made by the dip-switch located in the window on the side of the enclosure. By means of dip-switches it is possible to select the input type and range and the output type without recalibrate the device.

Moreover, by Personal Computer the user can program all the device's parameters, the type of mathematical function and the relative constant. It is possible to set the two output channels to calculate two independent functions.

The terminals of the current signal on input side must be only connected to active current loop.

The 1500 Vac galvanic isolation on all ways (inputs, outputs and power supply) eliminates the effects of all ground loops eventually existing and allows the use of the converter in heavy environmental conditions found in industrial applications.

It is housed in a plastic enclosure of 12.5 mm thickness suitable for DIN rail mounting in compliance with EN-50022 and EN-50035 standards.

USER INSTRUCTIONS

The converter must be powered by a direct voltage applied to the terminals Q and R.

The channel A measures the value from the sensor connected to the terminals I, L and G and transmits the output measure on the terminals N and M.

The channel B measures the value from the sensor connected to the terminals E, F and H and transmits the output measure on the terminals P and O.

The input and output connections must be made as shown in the section "Connections".

It is possible to configure the converter on field by dip-switch or Personal Computer as shown in the section " Programming ". The configuration by dip-switches can be made also if the device is powered (note: after the configuration the device takes some seconds to provide the right output measure).

TECHNICAL SPECIFICATIONS (Typical at 25 °C and in nominal conditions)

INPUT (2 CHANNELS)				OUTPUT (2 CHANNELS)				POWER SUPPLY	
Input type	Min	Max	Min.Span	Output type	Min	Max	Span min		
Voltage	0 V	10 V	1 V	Current	0 mA	20 mA	4 mA	Power supply voltage	18 .. 30 Vdc
Current	0 mA	20 mA	1 mA	Voltage	0 V	10 V	1 V	Reverse polarity protection	60 Vdc max
Input Calibration (1)				Output calibration				Current consumption	
Volt	the higher of $\pm 0.1\%$ f.s. and ± 2 mV			Current	± 7 μ A			Current output	55 mA max.
mA	the higher of $\pm 0.1\%$ f.s. and ± 6 μ A			Voltage	± 5 mV			Voltage output	25 mA max.
Linearity (1)				Burn-out values				ISOLATION	
Volt, mA	$\pm 0.05\%$ f.s.			Max. output value	22 mA or 10.6 V			Among all ways	1500 Vac, 50 Hz, 1 min
Input impedance				Output load Resistance - Rload				ENVIRONMENTAL CONDITIONS	
Voltage	≥ 1 M Ω			Current output	< 500 Ω			Operative Temperature	-20°C .. +60°C
Current	≤ 50 Ω			Voltage output	> 10 K Ω			Storage Temperature	-40°C.. +85°C
Thermal drift (1)				Short circuit current				Humidity (not condensed)	0 .. 90 %
Full scale	$\pm 0.01\%$ / °C			26 mA max.				Maximum Altitude	2000 m
				Response time (10+ 90%)				Installation	Indoor
				about 100 ms				Category of installation	II
								Pollution Degree	2
								MECHANICAL SPECIFICATIONS	
								Material	Self-extinguish plastic
								IP Code	IP20
								Wiring	wires with diameter 0.8+2.1 mm ² /AWG 14-18
								Tightening Torque	0.8 N m
								Mounting	in compliance with DIN rail standard EN-50022 and EN-50035
								Weight	about 90 g.
								CERTIFICATIONS	
								EMC (for industrial environments)	
								Immunity	EN 61000-6-2
								Emission	EN 61000-6-4

(1)referred to the input Span (difference between max. and min.)

PROGRAMMING

CONFIGURATION BY DIP-SWITCHES

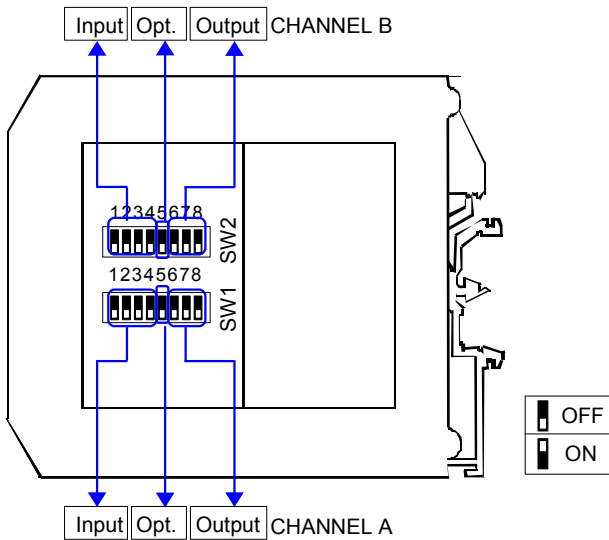

NOTE:
 - It is also possible to set the dip-switches using the wizard of the configuration software following the procedure described in the section "Configuration by PC".

1) Open the suitable door on the side of the device.

Configuration of Channel A (see TAB.1)

2) Set the input type by the dip-switch SW1 [1..4]

3) Set the output type by the dip-switch SW1 [6..8]

4) Set the options by the dip-switch SW1 [5]

Configuration of Channel B (see TAB.2)

2) Set the input type by the dip-switch SW2 [1..4]

3) Set the output type by the dip-switch SW2 [6..8]

4) Set the options by the dip-switch SW2 [5]

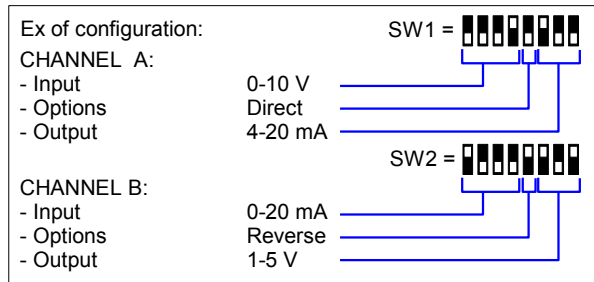

DIP-SWITCH CONFIGURATION TABLES

TAB.1 – Channel A settings

Input	Output	Options
SW1 1 2 3 4 Default *	SW1 6 7 8 0÷20 mA	SW1 5 Out: Direct
0÷20 mA	4÷20 mA	Reverse
4÷20 mA	0÷10 V	
0÷10 V	2÷10 V	
2÷10 V	0÷5 V	
0÷5 V	1÷5 V	
1÷5 V		

TAB.2 – Channel B settings

Input	Output	Options
SW2 1 2 3 4 Default *	SW2 6 7 8 0÷20 mA	SW2 5 Out: Direct
0÷20 mA	4÷20 mA	Reverse
4÷20 mA	0÷10 V	
0÷10 V	2÷10 V	
2÷10 V	0÷5 V	
0÷5 V	1÷5 V	
1÷5 V		

NOTES:

* If the dip-switches SWx [1..4] are all set in the position 0 ("Default"), the device will follow the configuration programmed by PC (Input and output type and options).

* Eventual wrong dip-switches settings will be signalled by the blinking of the led "PWR".

CONFIGURATION BY PC

By software DATESOFT it is possible to:

- set the default programming of the device;
- program the options not available with the dip-switch;
- read, in real time, the input and output measures;
- follow the dip-switches configuration wizard.

To configure the device follow the next steps:

- 1) Power-on the device.
- 2) Open the protection plastic label on the front of the device.
- 3) Connect the interface PRODAT to the PC (COM port) and to the device (PGRM connector).
- 4) Open DATESOFT.
- 5) Select the COM port in use.
- 6) Click on "Open COM".
- 7) Click on "Program".
- 8) Set the programming data.
- 9) Click on "Write" to send the programming data to the device.

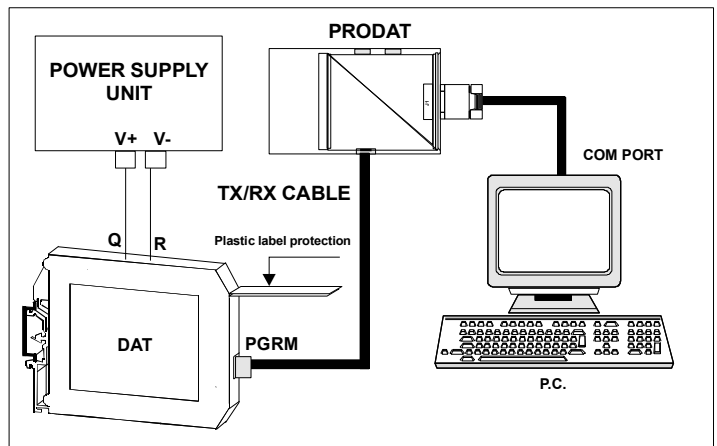

Warning: during these operations the device must always be powered and the TX/RX cable always connected.
For information about DATESOFT refer to the software's user guide.

CALCULATION FUNCTIONS

By the configuration software, it is possible to program the logic / mathematical functions listed below. For each function it is possible to program the proportionality factors of the input and output signals to adapt the analogue signal to the physical value of the actual application requested. The two output channels can be programmed with two independent functions.

Available functions:

- **= A** The output is proportional to the value measured on the input A.
- **= B** The output is proportional to the value measured on the input B.
- **A + B** The output is proportional to the sum between the value measured on the input A and the value measured on input B .
- **A - B** The output is proportional to the difference between the value measured on the input A and the value measured on input B .
- **A * B** The output is proportional to the multiplication between the value measured on the input A and the value measured on input B .
- **A / B** The output is proportional to the division between the value measured on the input A and the value measured on input B .
- **MAX (A,B)** The output is proportional to the higher value between the measures on the input A and which on input B .
- **MIN (A,B)** The output is proportional to the lower value between the measures on the input A and which on input B .

Examples:

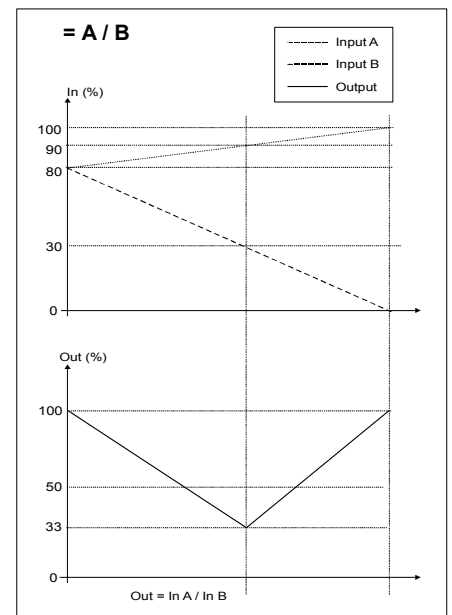
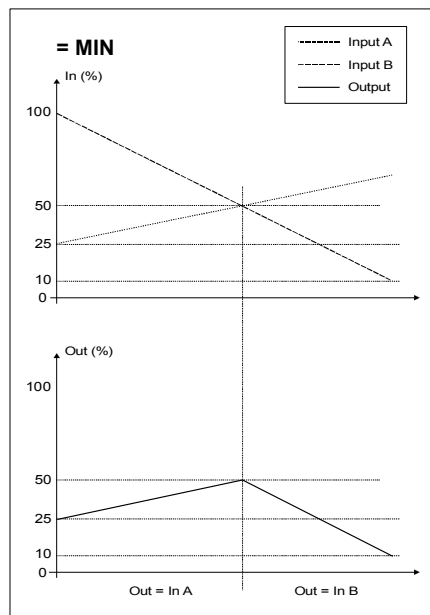
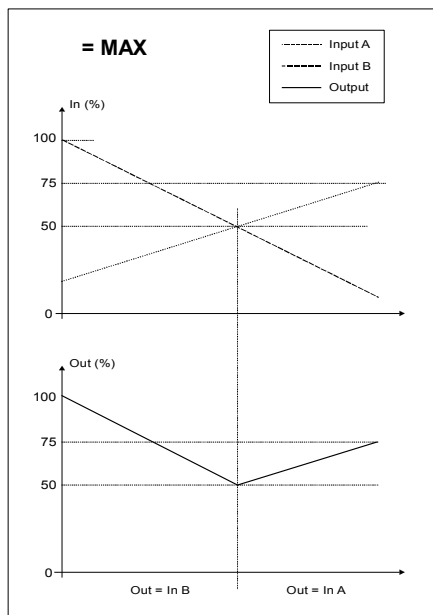
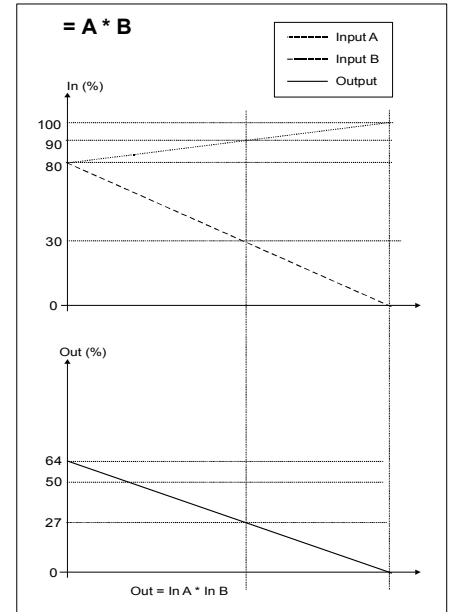
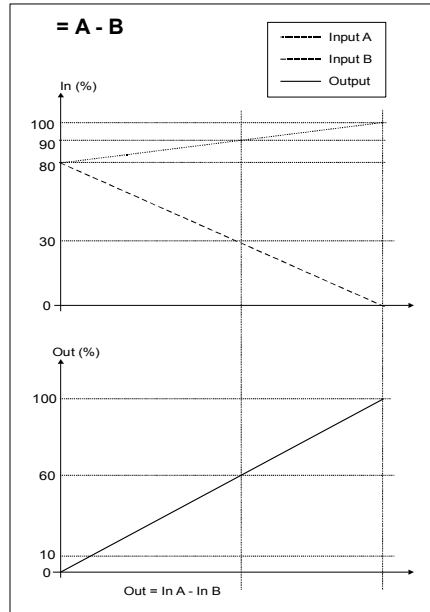
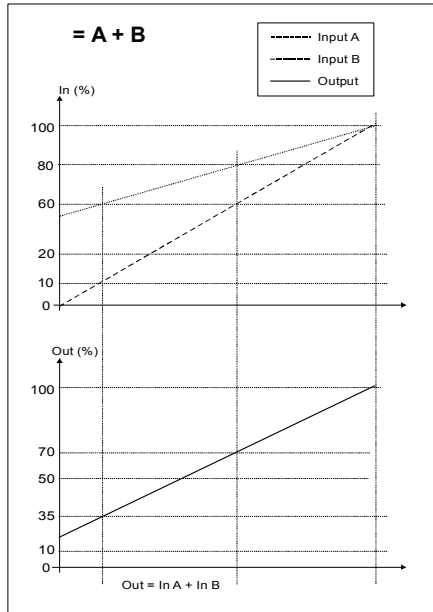

CONNECTIONS

INSTALLATION INSTRUCTIONS

The device is suitable for fitting to DIN rails in the vertical position. For optimum operation and long life follow these instructions:

When the devices are installed side by side it may be necessary to separate them by at least 5 mm in the following cases:

- If panel temperature exceeds 45°C.
- Use of high power supply value (> 27 Vdc).
- Use of output current.

Make sure that sufficient air flow is provided for the device avoiding to place raceways or other objects which could obstruct the ventilation slits. Moreover it is suggested to avoid that devices are mounted above appliances generating heat; their ideal place should be in the lower part of the panel.

Install the device in a place without vibrations.

Moreover it is suggested to avoid routing conductors near power signal cables (motors, induction ovens, inverters etc...) and to use shielded cable for connecting signals.

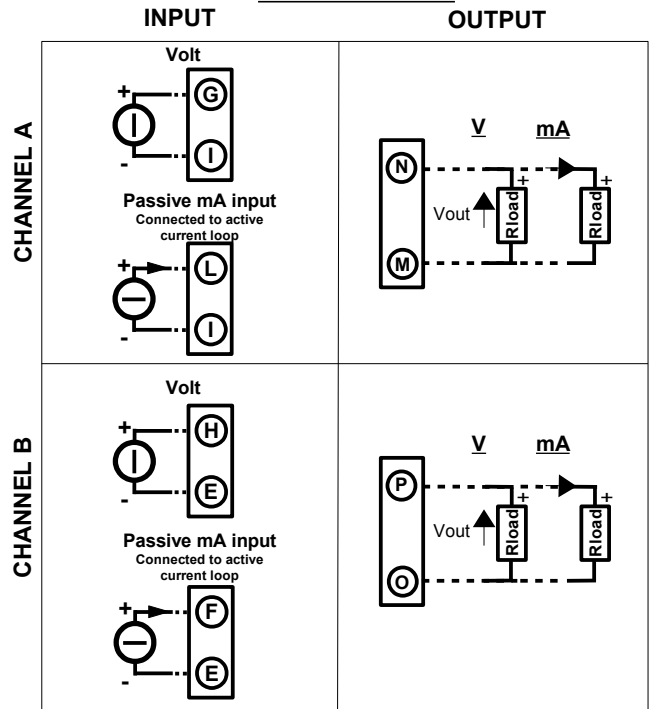

ISOLATION STRUCTURE

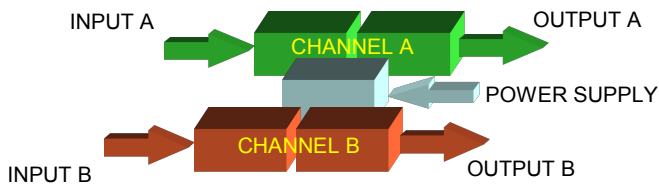

POWER SUPPLY

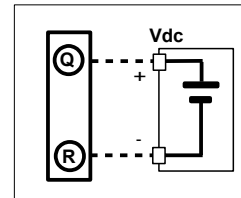

DIMENSIONS (mm)

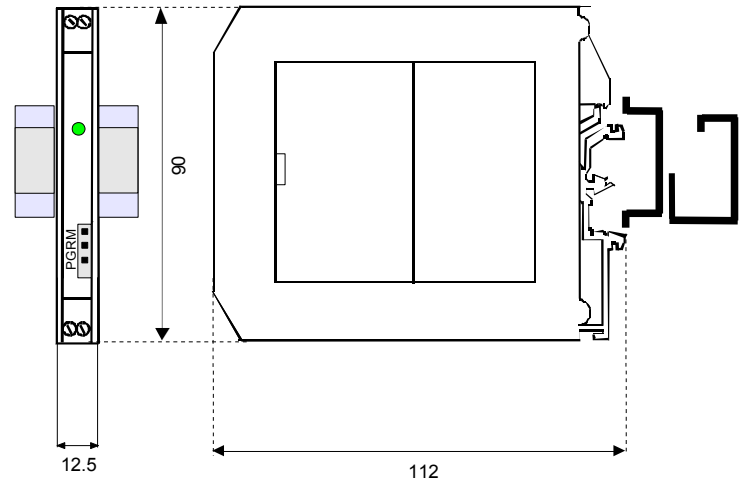

LIGHT SIGNALLING

LED	COLOUR	STATE	DESCRIPTION
PWR	GREEN	ON	Device powered
		OFF	Device not powered
		BLINKING	Wrong dip-switches setting

HOW TO ORDER

The device is provided as requested on the Customer's order. Refer to the section "Programming" to determine the input and output ranges. In case of the configuration is not specified, the parameters must be set by the user.

ORDER CODE EXAMPLE:

DAT 4632D / A=4 ÷ 20 mA / 4 ÷ 20 mA / A+B
B=4 ÷ 20 mA / 4 ÷ 20 mA / MAX

Campo scala ingresso

Campo scala uscita

Opzioni