



FEATURES

- 4÷20 mA loop powered
- Voltage Drop-out < 5V
- High accuracy and linearity
- 0.52" LED display
- Visualization configurable on the front side
- Connections on removable screw terminals
- Compact case size (DIN 48 x 96 mm)
- In compliance with EMC standards - CE mark



GENERAL DESCRIPTION

The digital panel indicator DAT 8050 accept on the input a 4 - 20 mA current loop signal. The input current signal is used to supply the device introducing a 5 Vdc voltage drop-out on the current loop, so is not required any external supply source. The user can program the visualisation of the measure in the range from -1999 up to 9999 points in order to set the values of the physical or electrical parameter transmitted on the current loop in the desired format. The programming of the visualization is made by the buttons "SET" and "ENTER" located on the front side of the instrument. By use of them, it is possible to program the values to be visualized correspondent to 4 mA and 20 mA and the position of the decimal point. It is possible to program the device on field. When the measured current is lower than 3.8 mA, the display will show the message " Lo "; in the same way, when the current measured is higher than 20.2 mA, the display will show the message " Hi ". Nearby the display it is possible to apply the desired engineering unit using the adhesive labels supplied with the device. The instrument set-up is particularly simple and cheap: the fixing system on panel (screw terminal type) and the program (by buttons), allow a quickly and economic installation. The DAT 8050 unit is housed into a strong plastic enclosure of 48 x 96 x 74 mm in according to the standard DIN43700.

USER INSTRUCTIONS

The DAT 8050 must be connected as shown in the section: "Connections". The input signal on terminal T1 is measured and converted in function of the scale of measure previously programmed ; such measure is visualised on the display. The same signal, on output , is supplied on the terminal T4 (DIAGRAM A). Between the terminals T1 and T4 there is a voltage drop lower than 5 V, necessary to supply the device. The terminals T2 and T3 are internally connected, and can be used to connect the ends of the return cable of the current loop eventually interrupted (DIAGRAM B). To program the visualization of the device refer to the section "Configuration and calibration". To install the device refer to the section "Installation Instructions".

TECHNICAL SPECIFICATIONS (Typical at 25 °C and in nominal conditions)

INPUT	
Input signal	4 - 20 mA
Voltage drop-out	< 5 V
Limitation current	< 50 mA
DISPLAY	
Type of visualization	4 digits LED
Digit height	0.52 "
Range of visualization(*)	programmable on the front side, from "-1999" up to"9999", with decimal point setting
Minimum measurable current	3.8 mA (visualization " Lo " in case of lower measure)
Maximum measurable current	20.2 mA (visualization " Hi " in case of higher measure)
CHARACTERISTICS AND PERFORMANCES	
Reading accuracy	the better than ± 0.05 % of f.s. or ± 1 digit.
Resolution	4 uA
Response time	< 0.5 sec.
Thermal drift	± 100 ppm/°C
Operating temperature	-20 ÷ 60 °C
Storage temperature	-40 ÷ 85 °C
Relative Humidity (not condensing)	0 ÷ 90%
Mechanical dimensions	48 x 96 x 74 mm
Maximum Altitude	2000 m
Installation	Indoor
Category of installation	II
Pollution Degree	2
Weight	approx. 100 g
Mechanical Specifications	
Material	Self-extinguishing plastic NORYL (UL94-V0)
IP Code	IP20
Wiring	wires with diameter 0.8÷2.1 mm ² /AWG 14-18
Tightening Torque	0.8 N m
Mounting	on Panel
Electromagnetic Compatibility (EMC) (for industrial environments)	Immunity: EN 61000-6-2 Emission: EN 61000-6-4
(*) : default visualization: 4.00 ÷ 20.00	

CONFIGURATION & CALIBRATION

In the chart in the side is shown the procedure to program the device.

The programming of the scale values and the decimal point is made by the buttons "ENTER" and "SET" located on the front side of the device. It is possible to do this operation in any moment giving to the instrument a current included in the $4 \div 20$ mA range.

The setting of the range is made in three steps:

- setting of full scale value
- setting of decimal point
- setting of begin scale value.

The value of the single digit can be set between "0" and "9"; to set a negative number, the value of the more significant digit (on the left) can also be set to "-" and "-1".

To set a number shorter of 4 digits (lower than 1000), set the more significant digits as "0".

The position of decimal point can be set nearby to each one of four digits. Set the decimal point on the right to visualize integer numbers.

If the more significant digit (from left to right) is as "0" an empty space will be displayed until the first valid digit, or the unit digit (example: the value -00.3 will be visualized as "- 0.3").

The use of buttons depends on the operation in progress.

The button ENTER:

- activates the procedure of configuration;
- confirms the modifies introduced from the user in each configuration step and allows to move to the next step.

The button SET:

- during the setting of the full and begin scale values, it increases the digit value; during the setting of decimal point, it moves its position to the left.
- cancels the modifies introduced from the user for each configuration step, moving to the next step.

NOTE: During the programming, if any button isn't pushed for at least 10 seconds, the device will automatically return in the measure condition, without save.

CONNECTIONS

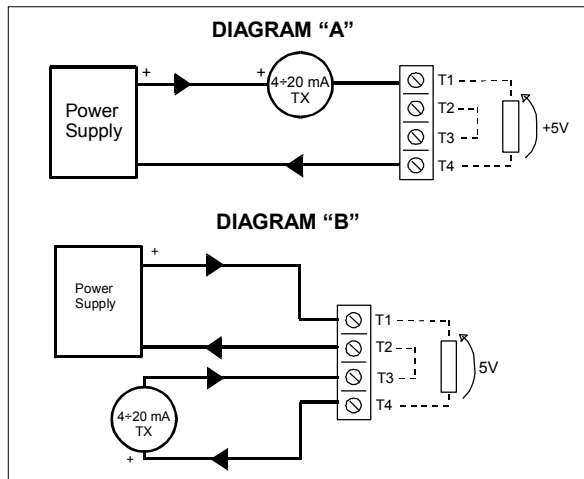

SCALE VALUES SETTING

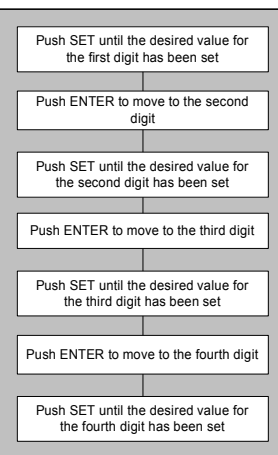

INSTALLATION INSTRUCTIONS

The device DAT 8050 is suitable for mounting on panel which must be fixed by the proper kit.

The device needs a panel cut-out of 92×45 mm (W * H).

It is necessary to install the device in a place without vibrations; avoid to routing conductors near power signal cables.

DIMENSIONS (mm) AND SETTINGS

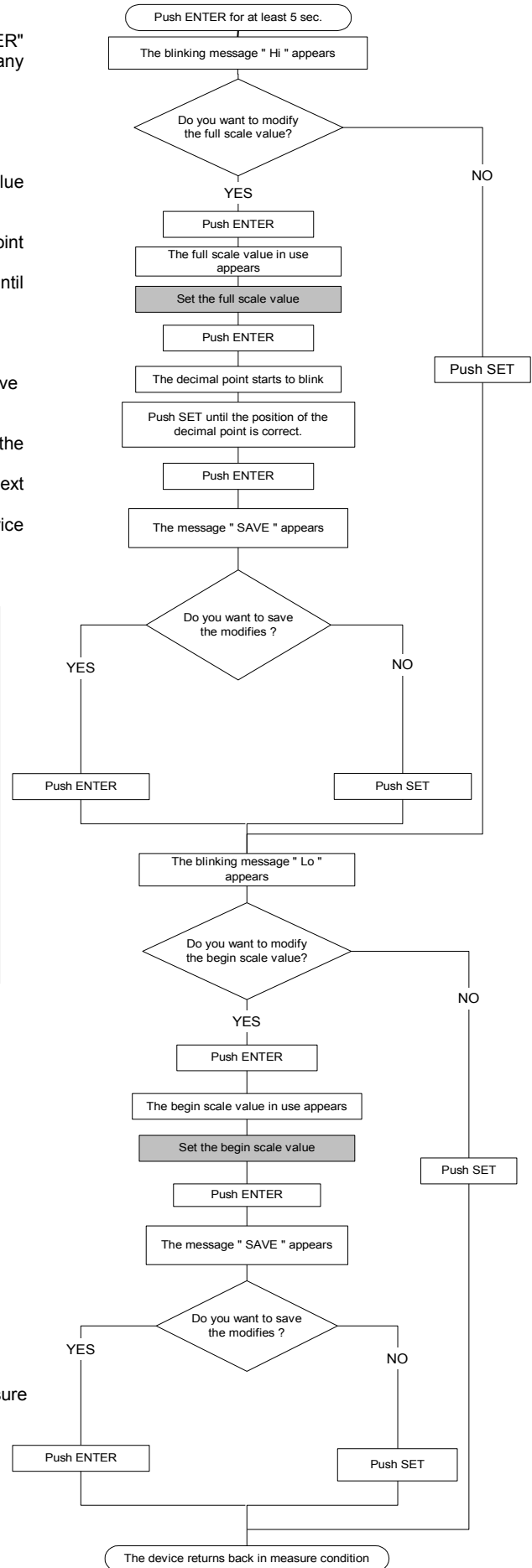
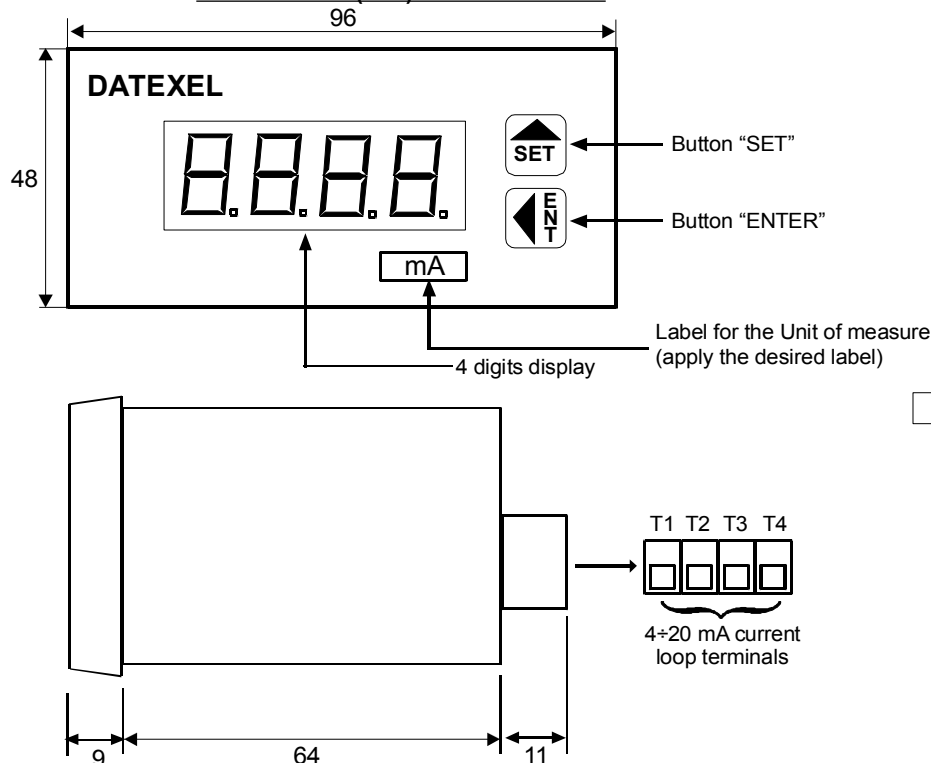

HOW TO ORDER

The DAT 8050 is supplied as request from the Customer in phase of order.

ORDER CODE: DAT 8050 - 0÷500

Range of visualization