

DAT 10016



FEATURES

- Modbus Slave device on RS-485
- Modbus RTU/ Modbus ASCII protocol
- 4 input channels for voltage up to ± 250 mV and thermocouples sensor type B, E, K, J, N, R, S, T
- Communication parameters configurable by dip-switches
- Watch-Dog Alarm
- Remotely Configurable
- 1500 Vac 3-ways Galvanic Isolation
- LEDs of signalling on front side for power supply and communication
- Connection by removable screw terminals
- High Accuracy
- CE mark
- DIN rail mounting in compliance with EN-50022

GENERAL DESCRIPTION

The device DAT10016 converts up to 4 analogue input signals into engineering units in digital format. The data are transmitted with MODBUS RTU / MODBUS ASCII protocol over the RS-485 network.

It is possible to connect on input 4 voltage signals up to ± 250 mV or thermocouples sensor type B, E, K, J, N, R, S, T. By programming, it is possible to execute the scaling of the measure of input up to ± 32768 points obtaining in the dedicated registers the measure of the channel in the desired format (ref. User Guide). The device guarantees high accuracy and stable measure versus time and temperature.

To ensure the plant safety, a Watch-Dog timer alarm is provided.

The isolation between the parts of circuit removes eventual ground-loop effects, allowing the use of the device even in the heavy environmental conditions.

The device is housed in a 6 module DIN rough self-extinguishing plastic box for mounting on EN-50022 standard DIN rail.

COMMUNICATION PROTOCOLS

The device is designed to work with the MODBUS RTU/MODBUS ASCII protocol: standard protocol in field-bus; allows to directly interface DAT10000 series devices to the larger part of PLCs and SCADA applications available on the market.

For the protocol instructions, refer to the User Guide of the device.

USER INSTRUCTIONS

Before to install the device, please read the "Installation Instruction" section.

It is possible to configure the device in two modes: by the dip-switches located on the front of the device or via software using the INIT modality.

Connect the terminal INIT to the terminal REF; at the power-on the device will be automatically set in the configuration set-up (refer to the User Guide of the device).

Connect power supply, serial bus and analogue inputs as shown in the "Wiring" section.

The LEDs state depends on the working condition of the device: see the "Light Signalling" section to verify the device working state.

To perform configuration and calibration operations, read the instructions in the User Guide of the device.

To simplify handling or replacing of the device, it is possible to remove the wired terminals even with the device powered.

TECHNICAL SPECIFICATIONS (Typical @ 25 °C and in the nominal conditions)

INPUT			Input Accuracy (1) mV, TC	> of $\pm 0.05\%$ f.s. or 5 μ V	POWER SUPPLY		
Input type	Min	Max					
Voltage			Linearity (1) mV TC	$\pm 0.1\%$ f.s. $\pm 0.2\%$ f.s.	Power supply voltage	10 .. 30 Vdc	
50 mV	-50 mV	+50 mV			Reverse polarity protection	60 Vdc max	
100 mV	-100 mV	+100 mV			Current consumption (operative)	35 mA max@24Vdc 45 mA max@10Vdc	
250 mV	-250 mV	+250 mV					
Thermocouple			CJC Compensation	± 1 °C	ISOLATION	Between all the ways	1500 Vac, 50 Hz, 1 min
J	-210 °C	+1200 °C	Input impedance mV,TC	≥ 1 M Ω	ENVIRONMENTAL CONDITIONS	Operative Temperature	-10°C .. +60°C
K	-210 °C	+1372 °C	Thermal drift (1) Full scale	$\pm 0.005\%$ / °C	Storage Temperature	-40°C.. +85°C	
R	-50 °C	+1767 °C	Thermal drift CJC Full scale	$\pm 0.02\%$ / °C	Humidity (not condensed)	0 .. 90 %	
S	-50 °C	+1767 °C	Line resistance influence (1) mV, TC	< 0.8 μ V/Ohm	Maximum Altitude	2000 m	
B	+400 °C	+1825 °C	Sample time	0.5 \div 1 sec.	Installation	Indoor	
E	-210 °C	+1000 °C	Warm-up time	3 min.	Category of installation	II	
T	-210 °C	+400 °C	Data Transmission (RS-485 asynchronous serial)		Pollution Degree	2	
N	-210 °C	+1300 °C	Baud Rate	115.2 Kbps	MECHANICAL SPECIFICATIONS	Material	Self-extinguish plastic
			Max. distance	1.2 Km – 4000 ft	IP Code	IP20	
					Wiring	wires with diameter	0.8 \div 2.1 mm ² /AWG 14-18
					Tightening Torque	0.5 N m	
					Mounting	in compliance with DIN rail standard EN-50022	
					Weight	about 200 g.	
					CERTIFICATIONS		
					EMC (for industrial environments)		
					Immunity	EN 61000-6-2	
					Emission	EN 61000-6-4	

(1) referred to the input Span (difference between max. and min.)

INSTALLATION INSTRUCTIONS

The DAT10016 is suitable for fitting to DIN rails in the vertical position. For optimum operation and long life follow these instructions:

When the devices are installed side by side it may be necessary to separate them by at least 5 mm in the following case:
- If panel temperature exceeds 45°C and power supply voltage 10 Vdc.

Make sure that sufficient air flow is provided for the device avoiding to place raceways or other objects which could obstruct the ventilation slits. Moreover it is suggested to avoid that devices are mounted above appliances generating heat; their ideal place should be in the lower part of the panel. Install the device in a place without vibrations.

Moreover it is suggested to avoid routing conductors near power signal cables (motors, induction ovens, inverters etc...) and to use shielded cable for connecting signals.

WIRING

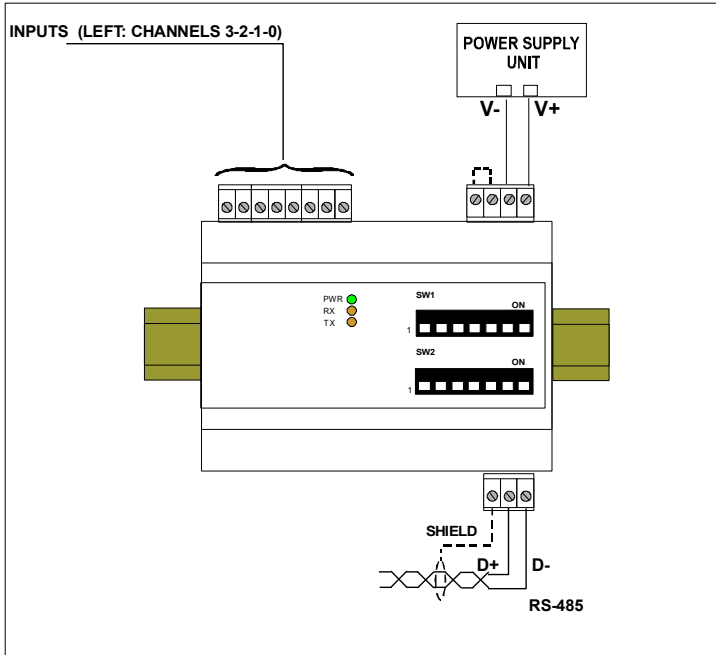

LIGHT SIGNALLING

LED	COLOUR	STATE	DESCRIPTION
PWR	GREEN	ON	Device powered
		OFF	Device not powered
		BLINK	~1 sec. - Watch-Dog alarm condition occurred
RX	ORANGE	BLINK	Stream of data over receiving line of RS-485
		OFF	No data over receiving line of RS-485
TX	ORANGE	BLINK	Stream of data over transmission line of RS-485
		OFF	No data over transmission line of RS-485

ISOLATION STRUCTURE



MECHANICAL DIMENSIONS (mm)

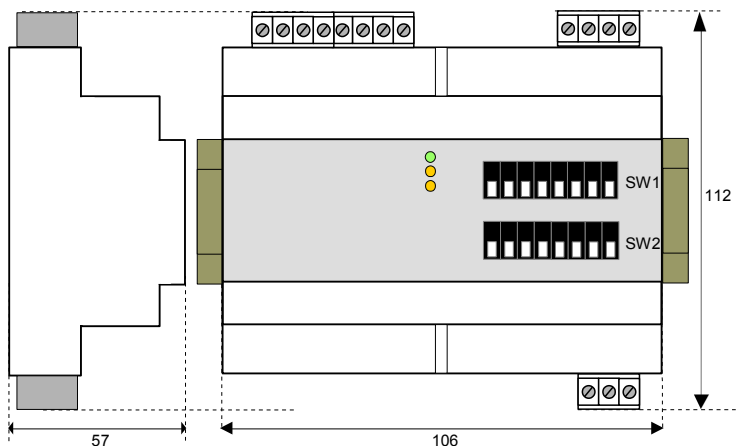

CONNECTIONS

ANALOGUE INPUTS

VOLTAGE

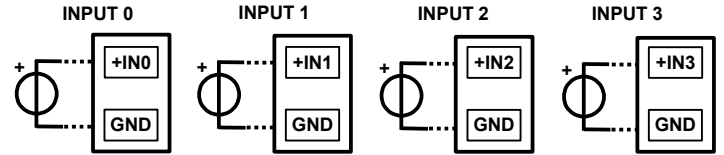

THERMOCOUPLES

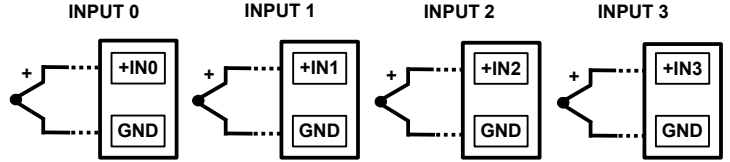

NOTE: the input channels are not isolated between them (terminal GND is common)

SERIAL LINE RS-485

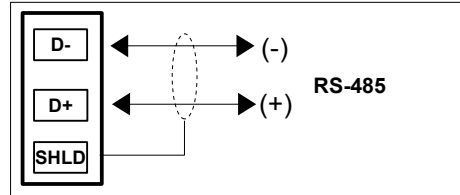

POWER SUPPLY

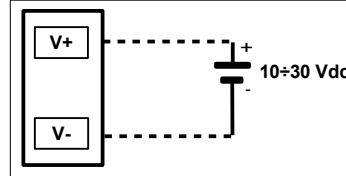

INIT

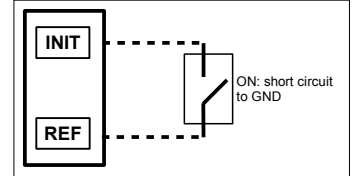

DIP-SWITCHES : TABLES OF CONFIGURATION

Warning: set all the dip-switches in OFF position to access to the device in EEPROM modality (the device will follow all the communication parameters set by software) or INIT. Power-off the device before to change the set of the dip-switches.

TAB.1 Modality settings (Pos.1)

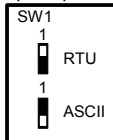

TAB.2 Parity settings (Pos.2 LSB; Pos.3 MSB)

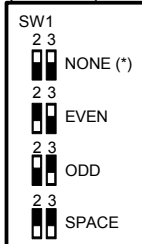

TAB.3 Baud rate settings (Pos.4 LSB; Pos.6 MSB)

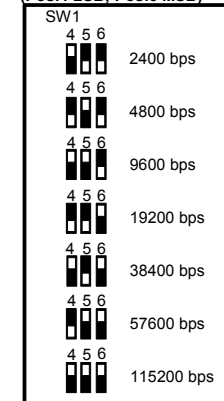

Note (*):

- in Modbus RTU Modality the setting is NONE; number of bit = 8
- in Modbus ASCII Modality the setting is MARK; number of bit = 7

DIP POSITION

ON OFF

HOW TO ORDER

The DAT10016 could be supplied as requested from the customer. Refer to the section "Technical Specifications" for the input type available.

DAT 10016 / TCK — Input type

